

MATRIX 220™



The Matrix 220 imager is the most compact image based barcode reader for top performance with the highest flexibility. It is the ideal imager reader for Electronics, Automotive, Packaging and Document Handling applications.

The Matrix 220 imager is designed for superior performance thanks to a 1.2 MPixel high resolution sensor and a new multicore image processing platform.

The innovative lighting solutions with an integrated flexible illumination system makes the Matrix 220 imager perfect for reading barcodes marked with DPM (Direct Part Marking). The Matrix 220 offers in a single model the polarized and diffused light options resulting in optimal illumination on any type of surface. The white, red and blue lights and the high powered illuminators models are capable of solving a huge variety of applications with the best performance. The electronic focus control allows easy remote job changing during assembly line reconfiguration with extreme reading flexibility.

The Matrix 220 imager has the best ease of use because of the green and red spot lights, the X-Press™ button, the intuitive HMI and the DL.CODE™ configuration software, which has been improved with the Automatic Setup mode for a quick and easy code reading.

ESD and Anti-YAG protection are available as front cover accessories to enhance the product flexibility reducing the number of models and simplifying the stock management.

The IP65 and IP67 industrial grade rating, the operating temperature range from -10 to 50 °C/14 to 122 °F and the new flexible cables guarantee the best quality and robustness in the Manufacturing Industry applications. The Matrix 220 imager offers cost-effective communication options with Power over Ethernet (PoE) connectivity and onboard PROFINET IO and ETHERNET/IP industrial fieldbus.

With its outstanding performance, the Matrix 220 imager delivers a high performance/price ratio offer in the Datalogic portfolio.



HIGHLIGHTS

- Ultra-compact dimensions and rotating connectors for easy integration and installation in tight spaces
- Industrial grade electronic focus on all models for extreme reading flexibility
- New All-In-One DPM illuminator. Red and blue-light polarizing filter and diffused illuminator on one model for many applications needs and strong DPM reading performances
- Top performing High Power Illuminators models for challenging high speed applications
- New multicore image processing platform excellent for high speed applications capable of reading up to 2 mils code resolution
- Hardware Acceleration to speed up algorithms and improve decoding capabilities
- Power over Ethernet option, onboard PROFINET IO and ETHERNET/IP for industrial connectivity
- Extreme industrial grade IP65 and IP67 ratings for harsh environments, -10 to 50 °C/14 to 122 °F operating temperature, new flexible cables suitable for robotic arms applications
- ESD and Anti-YAG protection as front cover accessory for extreme flexibility and optimized stock

APPLICATIONS

Electronics

- Track and trace PCB board manufacturing
- Electronic components (e.g. chip)
- Electronic products tracking
- DPM barcode reading (on plastic, glass, metal)

Automotive

- DPM code validation after marking
- Work-in-progress control
- Parts and assemblies traceability

Packaging

- Primary packaging barcode reading
- Package traceability

Food & Beverage

Document Handling

- High speed applications

TECHNICAL DATA

	Standard Model	Direct Part Marking Model
Dimensions	78mm x 47mm x 38mm (3.07 x 1.85 x 1.50 in) Connector at 0° 57mm x 47mm x 58mm (2.63 x 1.85 x 2.30 in) Connector at 90°	
Weight	173 gr (6,1 oz)	
Case Material	Aluminium case and plastic protective window cover	
Operating Temperature	-10 to 50°C (14 to 122 °F)	
Storage Temperature	-20 to 70 °C (-4 to 158 °F)	
Protection Class	IP65, IP67	
ESD Safe	YES, available as front cover accessory	
YAG Laser Protection	YES, available as front cover accessory	
ESD Safe and YAG Laser Protection	YES, available as front cover accessory	
Flexible Cables	YES, available as accessories	
Power Supply	All models except PoE: 10 VDC to 30 VDC PoE models: 48 VDC	
Max Power Consumption	All models except PoE: 4,2 Watt (10 VDC to 30 VDC) PoE models: 4,8 Watt (48 VDC)	
Sensor	Image resolution 1280 x 960 (1.2 megapixel) - 1/3" CMOS global shutter	
Frame Rate	45 frames/s	
Optical Focus Control	Electronic focus control	
Optical Models/Viewing Angles	7 mm (38,3°), 12 mm (24,1°)	
Reading Range	STD-W & STD-W HP Minimum: 40 mm Maximum: 400 mm (7 mm lens), 600 mm (12 mm lens)	DPM-R & DPM-B Minimum: 40 mm Maximum: 300 mm DPM-R HP Minimum: 40 mm Maximum: 400 mm (7 mm lens), 600 mm (12 mm lens)
Illumination	White light White high power light	Red light with polarizer and diffuser Red high power light with polarizer Blue light with polarizer and diffuser
Aiming System	2 Red Aimer LEDs	
Polarizing Filter	NO	YES embedded
Readable Symbologies	1D Codes: all standard 1 dimensional symbologies 2D Codes: Data Matrix, QR Code, Micro QR, Maxicode, Aztec, Dot code Postal Codes: Royal Mail, Japan Post, Planet, Postnet and many more	
Code Quality Metrics	1D CQ Standard: ISO/IEC 15416 2D CQ Standard: ISO/IEC 16022/18004, ISO/IEC 29158 (AIM-DPM), ISO/IEC 15415	
Embedded Communication Interfaces	All models except PoE: - Ethernet 10/100 Mbit/s: TCP/IP, UDP, FTP and Fieldbus PROFINET IO, Ethernet IP, Modbus TCP - Serial RS-232/RS422FD up to 115.2 Kbit/s + Serial Aux RS-232 PoE models: - Ethernet 10/100 Mbit/s PoE Mode A and Mode B: TCP/IP, UDP, FTP and Fieldbus PROFINET IO, Ethernet IP, Modbus TCP - Serial Aux RS-232	
Reader Networking	Datalogic ID-NET™	
Connectivity Modes	Pass Through, Master/Slave, Ethernet point to point	
Digital Inputs	All models except PoE: 2 inputs opto-coupled and polarity insensitive PoE models: 1 input opto-coupled and polarity insensitive	
Digital Outputs	3 Outputs (not available on PoE models): Configurable NPN, PNP, PP short-circuit protected Using CBX the first 2 outputs are opto-coupled	
User Interface	X-PRESS™ Human Machine Interface Beeper, Push Button, 7 LEDs (Status, Communication, Trigger, Good Read, Ready, Power on, Network) Green spot and Red spot LEDs Web Monitoring Interface	
Device Programming	DL.CODE™ Windows-based software (programming via Ethernet or Serial Interface) with Javascript output formatter Host Mode programming X-PRESS™	

DIMENSIONS

Dimensions in mm

MATRIX 220 - STRAIGHT CONNECTORS

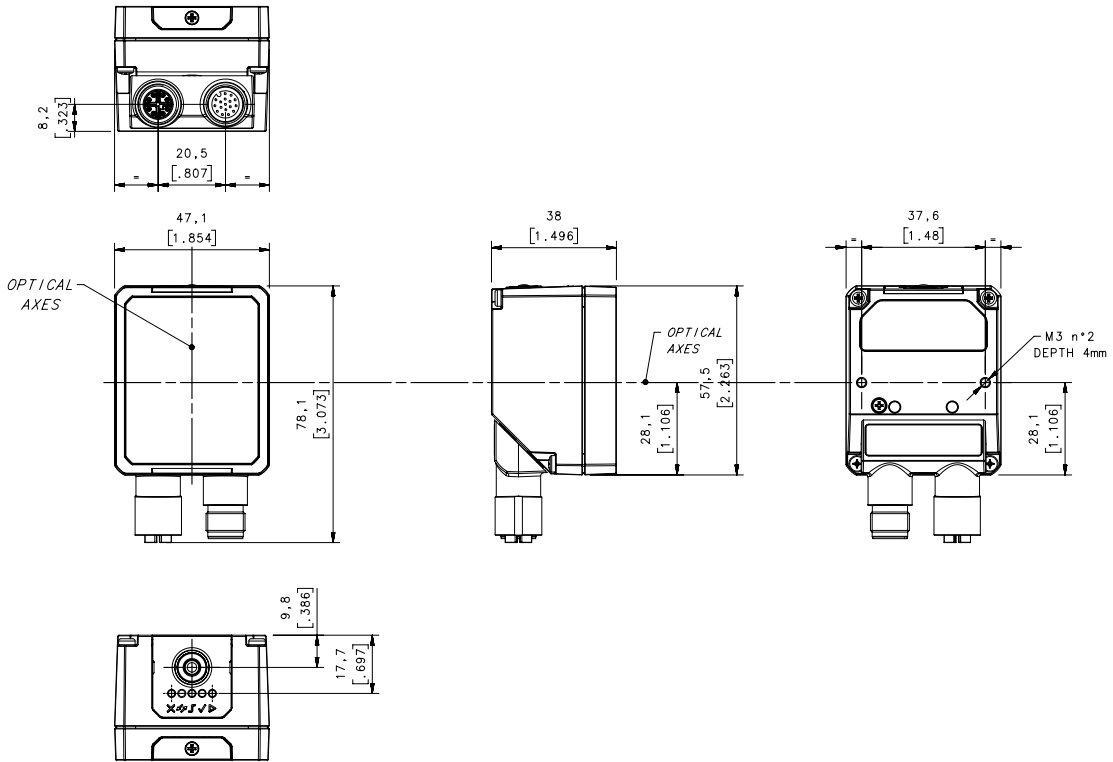

MATRIX 220 - STRAIGHT CONNECTORS & ESD/YAG COVER

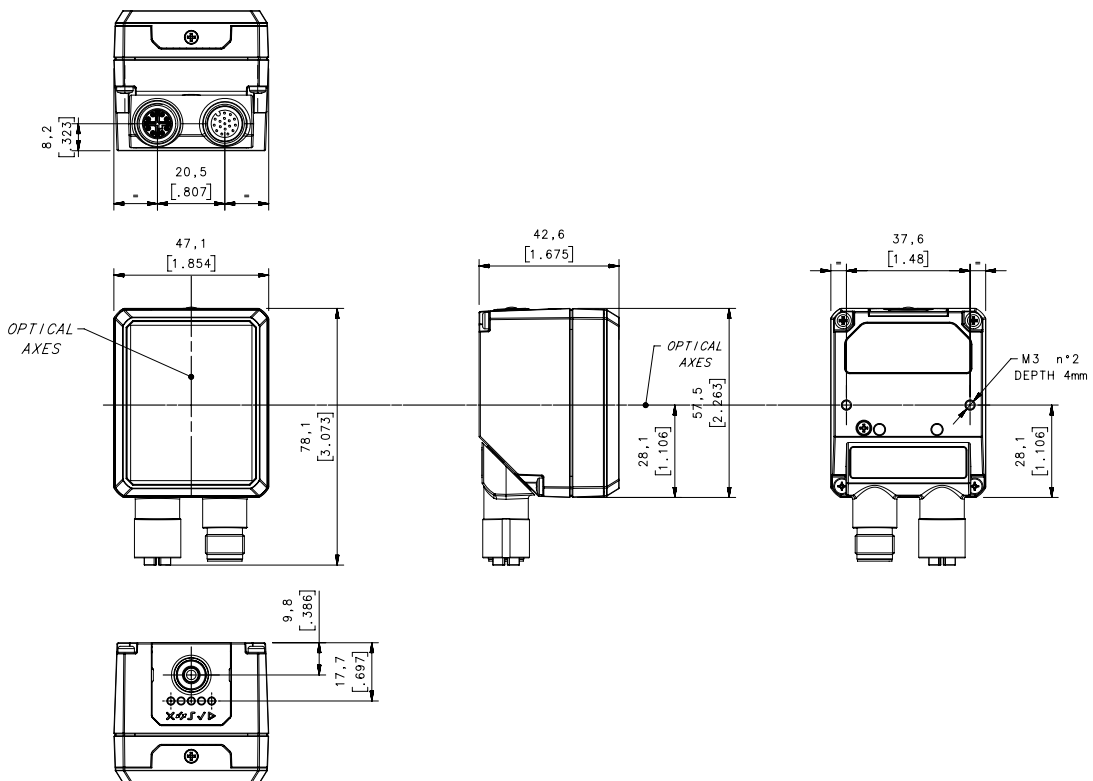

DIMENSIONS

Dimensions in mm

MATRIX 220 - 90° CONNECTORS

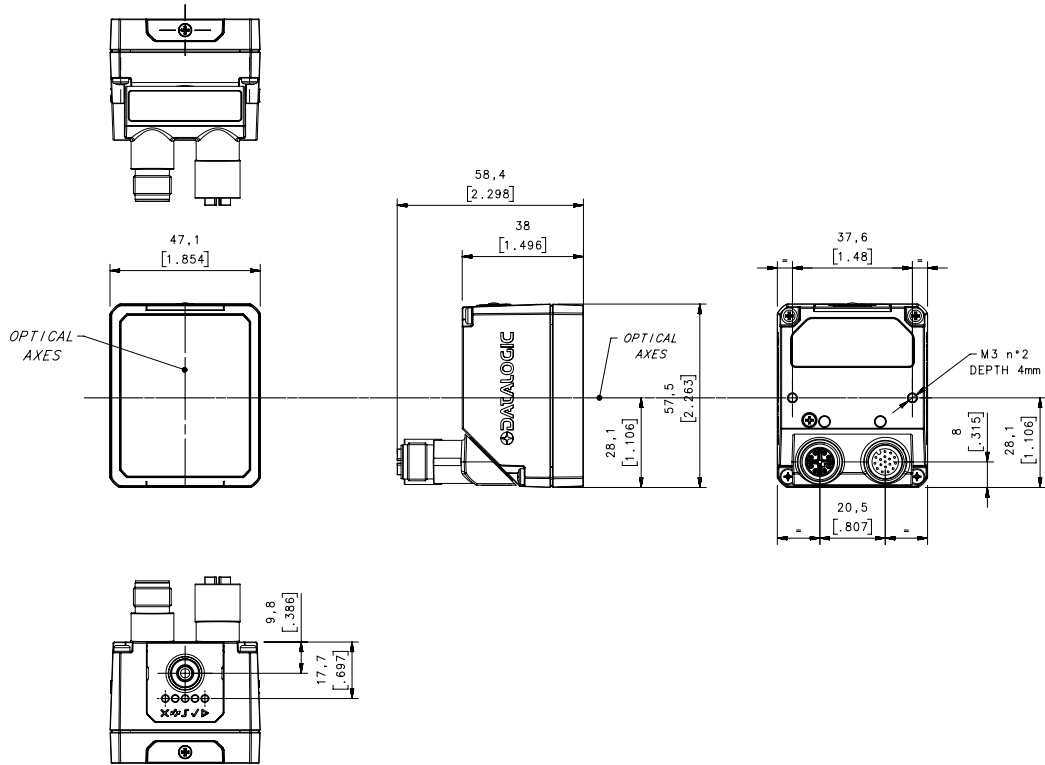

MATRIX 220 - 90° CONNECTORS & ESD/YAG COVER

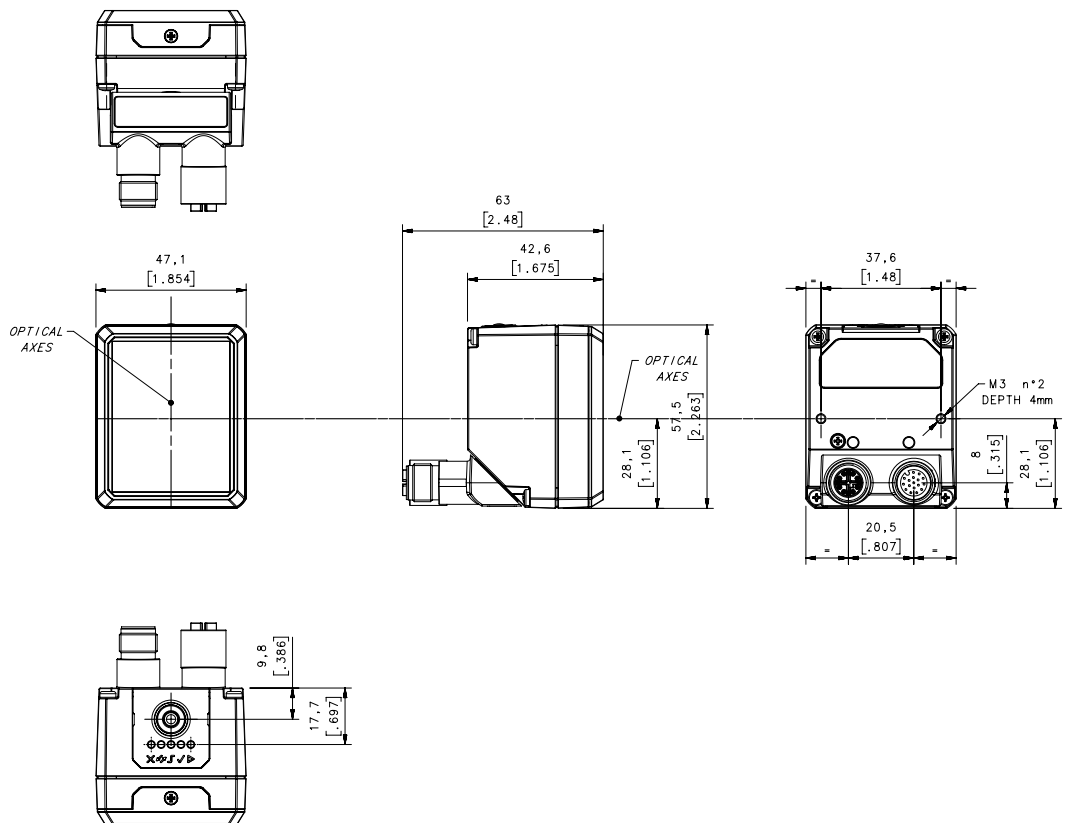

MODELS

P/N	DESCRIPTION	OPTICAL MODELS		ILLUMINATORS					CONNECTORS	
		7 mm	12 mm	STD-WHITE	DPM-RED	DPM-BLUE	STD-WHITE-HP	DPM-RED-HP	M12 17P + ETH	M12 5P + ETH POE
937900000	MATRIX 220 352-010 1.2MP STD-W 7MM	X		X					X	
937900001	MATRIX 220 355-010 1.2MP STD-W 12MM		X	X					X	
937900002	MATRIX 220 352-040 1.2MP STD-W 7MM POE	X		X						X
937900003	MATRIX 220 355-040 1.2MP STD-W 12MM POE		X	X						X
937900004	MATRIX 220 382-010 1.2MP DPM-R 7MM	X			X				X	
937900005	MATRIX 220 385-010 1.2MP DPM-R 12MM		X		X				X	
937900006	MATRIX 220 382-040 1.2MP DPM-R 7MM POE	X			X					X
937900007	MATRIX 220 385-040 1.2MP DPM-R 12MM POE		X		X					X
937900008	MATRIX 220 345-010 1.2MP STD-W 12MM HP		X				X		X	
937900009	MATRIX 220 305-010 1.2MP DPM-R 12MM HP		X					X	X	
937900010	MATRIX 220 302-010 1.2MP DPM-R 7MM HP	X						X	X	
937900011	MATRIX 220 392-010 1.2MP DPM-B 7MM	X				X			X	
937900012	MATRIX 220 395-010 1.2MP DPM-B 12MM		X			X			X	
937900013	MATRIX 220 392-040 1.2MP DPM-B 7MM POE	X				X				X
937900014	MATRIX 220 395-040 1.2MP DPM-B 12MM POE		X			X				X

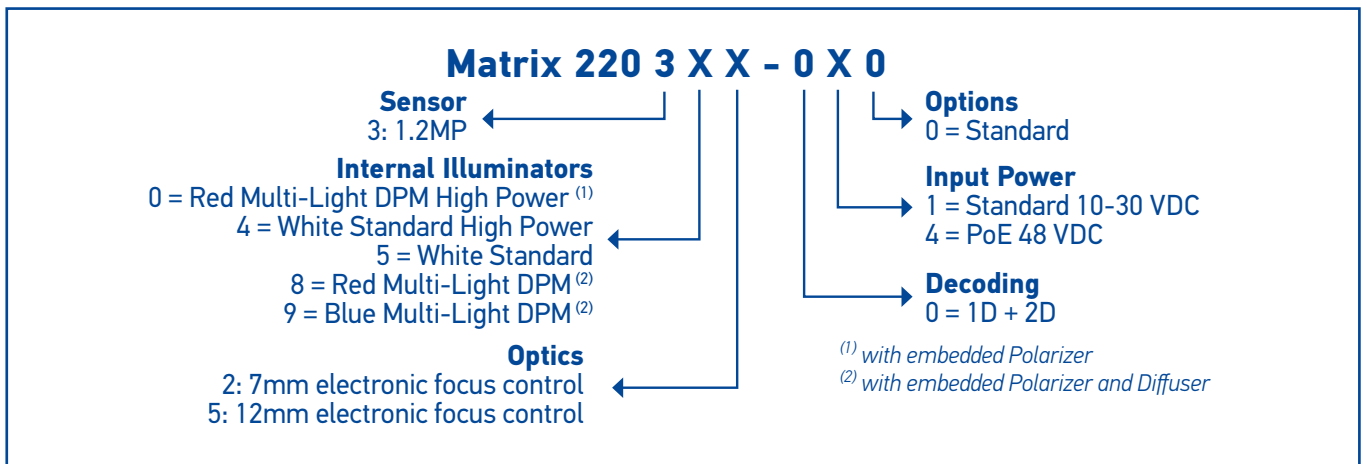

CONFIGURATION	LEDs ON	LEDs COLOR
Model: Standard		
1	4 (Top + Bottom)	White
2	2 (Top)	White
3	2 (Bottom)	White
DPM (Red Light)		
1	12 Diffused (Top + Bottom)	Red
2	6 Diffused (Top)	Red
3	6 Diffused (Bottom)	Red
4	2 Non Polarized	Red
5	2 Polarized	Red
DPM (Blue Light)		
1	12 Diffused (Top + Bottom)	Blue
2	6 Diffused (Top)	Blue
3	6 Diffused (Bottom)	Blue
4	2 Non Polarized	Blue
5	2 Polarized	Blue
Model: Standard (High Power)		
1	8 (Central Chain + Top/Bottom Chain)	White
2	4 (Central Chain)	White
3	4 (Top/Bottom Chain)	White
Model: DPM (High Power)		
1	4 Polarized	Red
2	4 Non Polarized	Red



ACCESSORIES

CATEGORY	PART NUMBER	DESCRIPTION
Cables	93A050058	M12-IP67 Cable To CBX or QL (1M)
	93A050059	M12-IP67 Cable To CBX or QL (3M)
	93A050060	M12-IP67 Cable To CBX or QL (5M)
	93A050116	M12-IP67 17p Flexible Cable To CBX or QL (1M)*
	93A050117	M12-IP67 17p Flexible Cable To CBX or QL (3M)*
	93A050118	M12-IP67 17p Flexible Cable To CBX or QL (5M)*
	93A050122	M12-IP67 GIGA Ethernet Cable X-Coded (1M)
	93A050123	M12-IP67 GIGA Ethernet Cable X-Coded (3M)
	93A050124	M12-IP67 GIGA Ethernet Cable X-Coded (5M)
	93A050125	M12-IP67 GIGA Ethernet Flexible Cable X-Coded (1M)*
	93A050126	M12-IP67 GIGA Ethernet Flexible Cable X-Coded (3M)*
	93A050127	M12-IP67 GIGA Ethernet Flexible Cable X-Coded (5M)*
	93A050128	Adapter Cable GIGA Ethernet X-Coded M12 to RJ45
	93A050129	Adapter Cable GIGA Ethernet X-Coded to Ethernet D-Coded
	Front covers	93ACC0227
93ACC0228		YAG Cut Filter Window Cover M220
93ACC0229		ESD Safe YAG Cut Filter Win Cover M220
Bracket	93ACC0230	BK-22-000 Fixing Bracket M220 Body

* Suitable for robotic arms applications



Rev. 01_03/2019